

## Submersible drainage pumps

 Clear water

 Domestic use

 Civil use

### PERFORMANCE RANGE

- Flow rate up to **300 l/min** (18 m<sup>3</sup>/h)
- Head up to **26 m**

### APPLICATION LIMITS

- **5 m** maximum immersion depth (with a sufficiently long power cable)
- Maximum liquid temperature **+40 °C**
- Passage of suspended solids up to **Ø 10 mm**
- Suction down to **17 mm** above ground level
- Minimum immersion depth for continuous service: **220 mm**

### CONSTRUCTION AND SAFETY STANDARDS

- Power cable length:
  - **5 m** for D8, D10, D20
  - **10 m** for D30
- Float switch for single-phase versions

EN 60335-1  
IEC 60335-1  
CEI 61-150

EN 60034-1  
IEC 60034-1  
CEI 2-3



### CERTIFICATIONS

Company with management system certified DNV  
ISO 9001: QUALITY

### INSTALLATION AND USE

Designed for draining **clear or slightly dirty water**, the **D** series pumps are recommended for domestic, civil and professional applications for draining flooded interiors such as basements and garages, for emptying swimming pools and tanks, for disposal of waste water which is not sewage.

These pumps distinguish themselves for their reliability, which can be best appreciated under automatic operating conditions in fixed installations.

### PATENTS - TRADE MARKS - MODELS

- Patent n. EP2313658
- Patent n. IT0001428923

### OPTIONS AVAILABLE ON REQUEST

- D8-10-20 pumps with a **10 m** power cable.
  - ➡ N.B.: Standard EN 60335-2-41 states that the power cable must be 10 m long for outdoor applications
- Single-phase pumps without float switch
- Other voltages

### GUARANTEE

2 years subject to terms and conditions

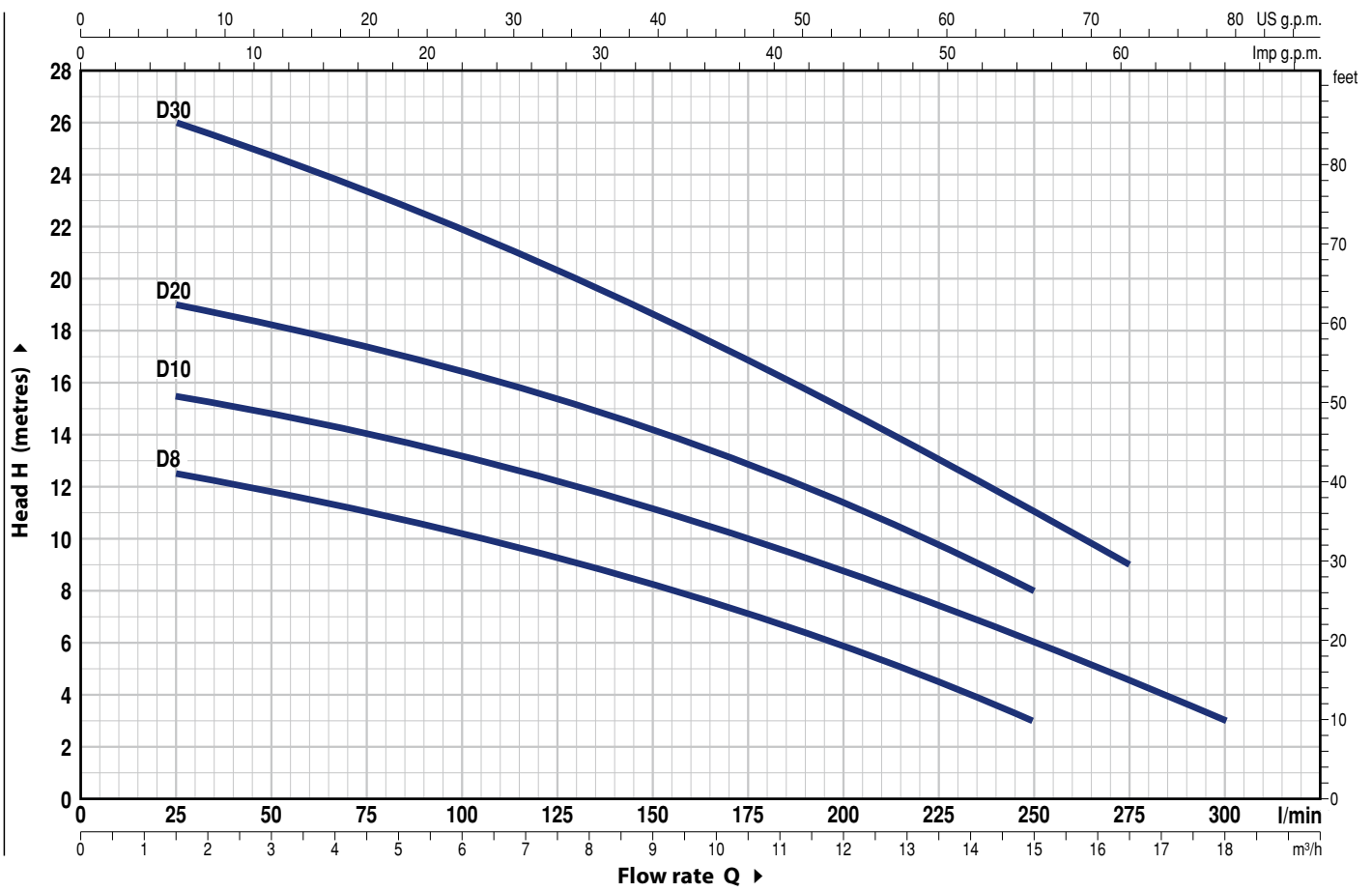
**CHARACTERISTIC CURVES AND PERFORMANCE DATA**
**60 Hz n= 3450 min<sup>-1</sup>**

MODEL		POWER (P <sub>2</sub> )		Q	Flow rate																	
Single-phase	Three-phase	kW	HP		m <sup>3</sup> /h	0	1.5	3.0	4.5	6.0	7.5	9.0	10.5	12.0	13.2	15.0	16.5	18.0				
				l/min	0	25	50	75	100	125	150	175	200	220	250	275	300					
Dm 8	D 8	0.55	0.75	H metres	13	12.5	12	11	10	9	8	7	6	4.7	3							
Dm 10	D 10	0.75	1		16	15.5	15	14	13.2	12.2	11.2	10	8.8	7.8	6	4.5	3					
Dm 20	D 20	0.75	1		20	19	18.5	17.5	16.5	15.5	14.3	13	11.5	10	8							
Dm 30	D 30	1.1	1.5		26	26	25	23.5	22	20.5	18.7	17	15	13.5	11	9						

**Q** = Flow rate **H** = Total manometric head

Tolerance of characteristic curves in compliance with EN ISO 9906 Grade 3B.

**POS. COMPONENT CONSTRUCTION CHARACTERISTICS**

<b>1 PUMP BODY</b>	Cast iron with an Epoxy Electro Coating treatment, with threaded port in compliance with ISO 228/1
<b>2 SUCTION FILTER</b>	Stainless steel AISI 304
<b>3 SUCTION PLATE</b>	Stainless steel AISI 304
<b>4 IMPELLER</b>	Technopolymer open type
<b>5 MOTOR CASING</b>	Stainless steel AISI 304
<b>6 MOTOR CASING PLATE</b>	Stainless steel AISI 304
<b>7 MOTOR SHAFT</b>	Stainless steel AISI 431

**8 SHAFT WITH DOUBLE MECHANICAL SEAL SEPARATED BY AN OIL CHAMBER**

<i>Pump Model</i>	<i>Seal Model</i>	<i>Shaft Diameter</i>	<i>Position</i>	<i>Materials</i>		
				<i>Stationary ring</i>	<i>Rotational ring</i>	<i>Elastomer</i>
<b>D8</b>	<b>MG1-14D SIC</b>	<b>Ø 14 mm</b>	Motor side	Silicon carbide	Graphite	NBR
<b>D10</b>			Pump side	Silicon carbide	Silicon carbide	NBR
<b>D20</b>			Pump side	Silicon carbide	Silicon carbide	NBR
<b>(Double seal on shaft with a ring seal Ø 16 x Ø 24 x H 5 mm)</b>						
<b>D30</b>	<b>ST1-14 SIC</b>	<b>Ø 14 mm</b>		Ceramic	Silicon carbide	NBR

**9 BEARINGS 6203 ZZ / 6203 ZZ**
**10 CAPACITOR**

<i>Pump Single-phase</i>	<i>Capacitance (220 V) (110 V or 127 V)</i>	
<b>Dm8</b>	<b>20 µF - 450 VL</b>	<b>30 µF - 250 VL</b>
<b>Dm10</b>		
<b>Dm20</b>	<b>25 µF - 450 VL</b>	-
<b>Dm30</b>		

**11 ELECTRIC MOTOR**

**Dm:** single-phase 220 V - 60 Hz  
with thermal overload protector incorporated into the winding  
**D:** three-phase 380 V - 60 Hz  
– Insulation: class F  
– Protection: IP X8

**12 POWER CABLE**

“H07 RN-F” type  
(with Schuko plug for single-phase versions only)  
**Standard length 5 metres (10 metres for D30)**

**13 FLOAT SWITCH**

(only for single-phase versions)

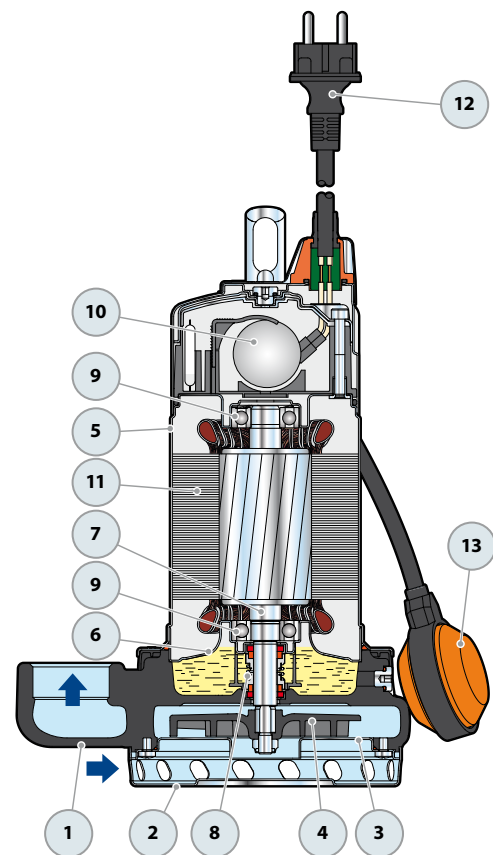

## DIMENSIONS AND WEIGHT

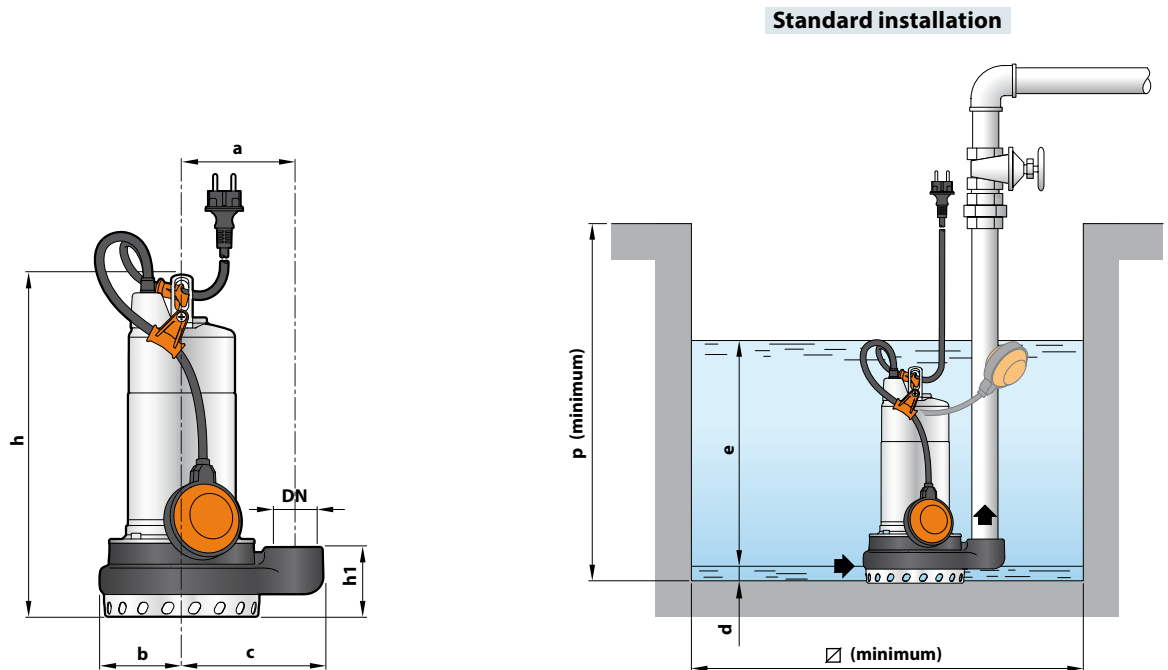

MODEL		PORT DN	DIMENSIONS mm									kg	
Single-phase	Three-phase		a	b	c	h	h1	d	e	p	∅	1~	3~
Dm 8	D 8	1½"	115	85	147	344	73	17	variable	500	500	12.0	11.7
Dm 10	D 10											12.9	11.7
Dm 20	D 20			12.9	11.9								
Dm 30	D 30			93	358	84	15.1	14.0					

## ABSORPTION

MODEL	VOLTAGE		
	Single-phase	220 V	110 V
Dm 8	3.8 A	7.6 A	6.8 A
Dm 10	5.0 A	10.0 A	9.5 A
Dm 20	6.5 A	13.0 A	11.5 A
Dm 30	7.7 A	15.4 A	13.3 A

MODEL	VOLTAGE		
	Three-phase	220 V	380 V
D 8	3.2 A	1.8 A	1.6 A
D 10	3.9 A	2.3 A	2.0 A
D 20	4.9 A	2.8 A	2.5 A
D 30	5.7 A	3.3 A	2.9 A

## PALLETIZATION

MODEL		GROUPAGE n. pumps	CONTAINER n. pumps
Single-phase	Three-phase		
Dm 8	D 8	60	80
Dm 10	D 10	60	80
Dm 20	D 20	60	80
Dm 30	D 30	60	80